

SMA6100-9L240

**SMA Reverse Polarity  
Crimp Plug Right Angle**

**50Ω**

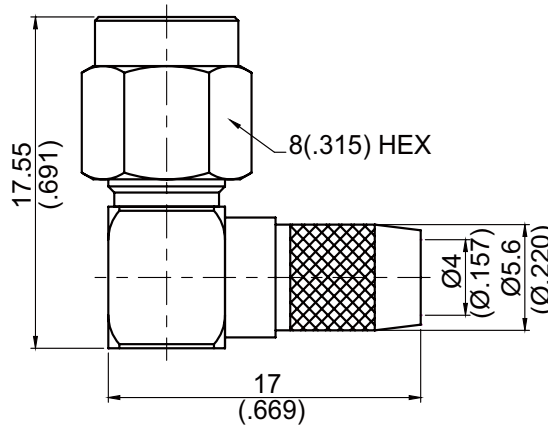

Parts	Material	Plating (Micro-inch)
Ferrule	Brass	Gold 4 Over Nickel Phosphorous Alloy 80 Over Copper 20
Cover	Brass	Gold 4 Over Nickel Phosphorous Alloy 80 Over Copper 20
Retainer Ring	Beryllium Copper	Tin-Zinc-Copper-Alloy 100 Over Copper 50
Gasket	Silicon	
Contact Pin	Beryllium Copper	Gold 4 Over Nickel Phosphorous Alloy 80 Over Copper 20
Insulator	Teflon	
Barrel	Brass	Gold 4 Over Nickel Phosphorous Alloy 80 Over Copper 20
Body	Brass	Gold 4 Over Nickel Phosphorous Alloy 80 Over Copper 20
Coupling Nut	Brass	Gold 4 Over Nickel Phosphorous Alloy 80 Over Copper 20

Weight:

Suitable Cables: JBY240; LMR240

**This part number complies with RoHS.**

**Notice: JYEBAO reserves the right to make modifications deemed appropriate.**

## CABLE ASSEMBLY INSTRUCTION

SMA6100-9L240

**JYE BAO CO., LTD.**  
**TAIPEI TAIWAN R.O.C**

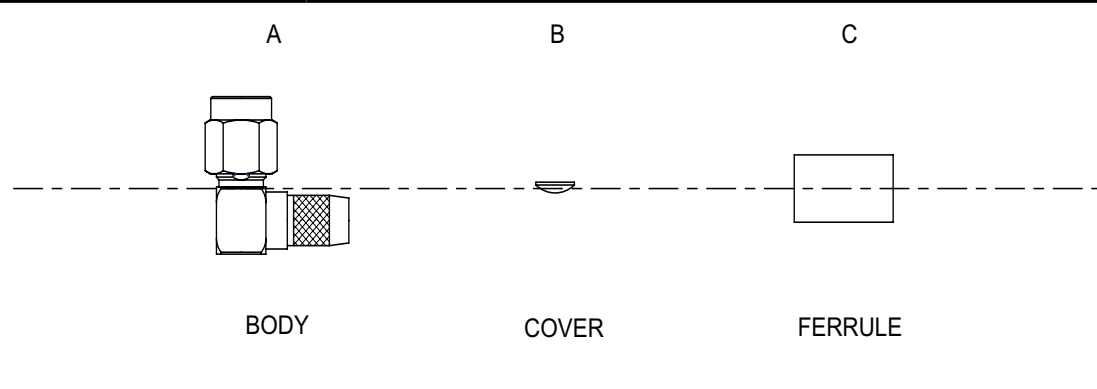

DIAGRAM	ASSEMBLY INSTRUCTION
	<p>Step 1: STRIP AS SHOWN.</p>
	<p>Step 2: SLIDE FERRULE " C " OVER CABLE.                      Step 3: WRAP THE BRAIDING UPWARDS.                      Step 4: SLIDE CENTER CONDUCTOR ON THE CONTACT PIN OF CONNECTOR " A " AND SOLDER IN " Y ".</p>
	<p>Step 5: SLIDE FERRULE " C " TOWARDS THE CONNECTOR " A " AND CRIMP.                      (USE 6.5mm/0.256inch HEX SECTION OF INSERT-E)</p>
	<p>Step 6: PRESS ON THE TOP OF " B " WITH JIGS.</p>

**This part number complies with RoHS.**

**Notice: JYEBAO reserves the right to make modifications deemed appropriate.**