

**N8146A-0178** **N Jack Crimp For Panel Receptacle** **50Ω**

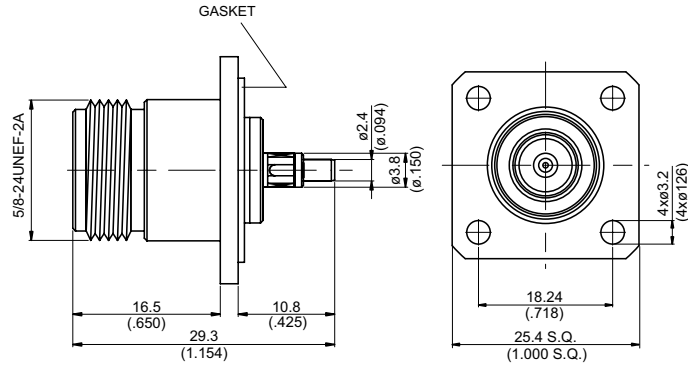

**MOUNTING HOLE**

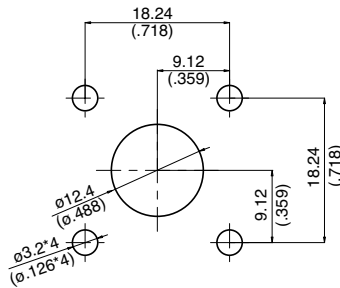

Parts	Material	Plating (Micro-inch)
Gasket	Silicon	
Ferrule	Brass	Tin-Zinc-Copper-Alloy 100 Over Copper 50
Cover	Brass	Tin-Zinc-Copper-Alloy 100 Over Copper 50
Barrel	Brass	Tin-Zinc-Copper-Alloy 100 Over Copper 50
Contact Pin	Beryllium Copper	Gold 4 Over Nickel Phosphorus Alloy 80 Over Copper 20
Insulator	Teflon	
Body	Brass	Tin-Zinc-Copper-Alloy 100 Over Copper 50

Weight:  
Suitable Cables: RG178, RG178-FEP, RG196

**This part number complies with RoHS.**

**Notice: JYEBAO reserves the right to make modifications deemed appropriate.**

## CABLE ASSEMBLY INSTRUCTION

N8146A-0178

JYE BAO CO., LTD.

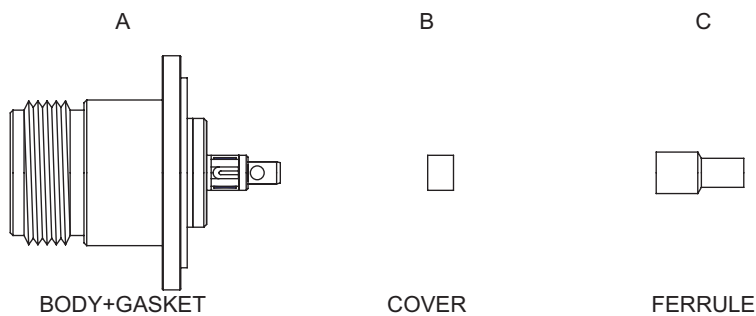

DIAGRAM	ASSEMBLY INSTRUCTION
	<p>Step 1: STRIP AS SHOWN .</p>
	<p>Step 2: TIN DIP BRAIDING. Step 3: SLIDE FERRULE " C " OVER CABLE .</p>
	<p>Step 3: INSERT CABLE'S CENTER CONDUCTOR INTO CONNECTOR BODY " A " AND SOLDER IN " Y " .</p>
	<p>Step 4: PUT COVER " B " ON BODY " A " .</p>
	<p>Step 5: SLIDE FERRULE " C " TOWARDS THE CONNECTOR " A " AND CRIMP.</p>

This part number complies with RoHS.

Notice: JYEBAO reserves the right to make modifications deemed appropriate.